

ZS210

BERTOLI



The mobile plant ZS210, for its highly innovative constructive conception, allows to transport all necessary elements for concrete production (inert, cement, water, chemical additives) separated in suitable containers and to extract proportionally the elements while unloading, continuously, according to parameters chosen by the operator.

Separated transportation of elements

The mobile plant ZS210 separately transports the elements for concrete production and allows the operator to vary the concrete blend while unloading.

It allows to mix "soft" or "hard" concretes. It's also possible to mix concretes "rich" or "poor" of water.

Variations are quick, precise, verified by visual signals on a display and they can be executed with working plant without stopping the production.

ZS210 operating

The mobile plant ZS210 has a conveyor belt for inerts. It extract a fixed defined quantity of inert, for the whole width of the belt (with a variable height from 1 to about 14 cm), that goes to the mixer. During the mixing, the cement (extracted by a cochlea and weight-controlled by loss-in-weight load cells), the water and possible additives are added; all the system is controlled by a PLC fitted with the plant.

The flow variation of inert is obtained by adjusting the gates, the cement has a fixed flow and the water flow is variable by a manual membrane valve.

ZS210 TECHNICAL DATA

Mobile plant for concrete production

Description	Unit	
CAPACITY		
Max production	mc/h	10
Working temperature range	°C	-20/+50 °C
DOSAGE		
Volume water tank	mc	1
Volume cement hopper	mc	0,7
Volume inert hopper	mc	2
DIMENSIONS AND WEIGHTS		
Max. Height from support plane	mm	2150
Width	mm	1570
Length	mm	4150
Total weight vacuum machine	N	22.000 (Kg 2.200)
MIXER		
Max. Vertical shift		20°
ENGINE		
Max. power	HP	35
Rpm	rpm	2200
CONTROL PANEL CHARACTERISTICS		
Size		6,5"
Transflective color display with function buttons		
Setting menus		50

Quoted data are merely notional. All informations on this document are subject to change without notice

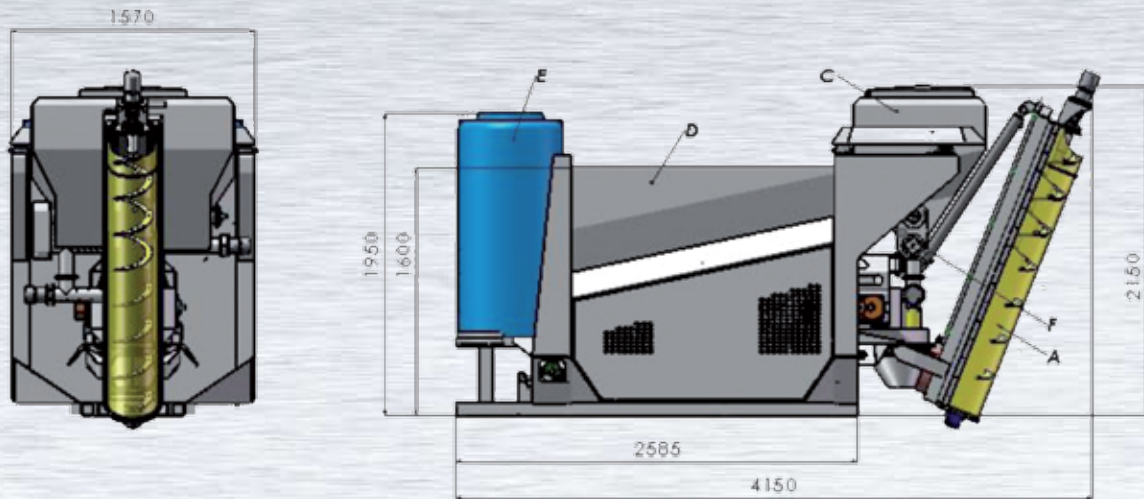

Moving mixer with manual swivel and hydraulic vertical shift

- A: Mixer
- B: Diesel Engine
- C: Cement hopper
- D: Inert hopper
- E: Water tank
- F: Extracting cochlea

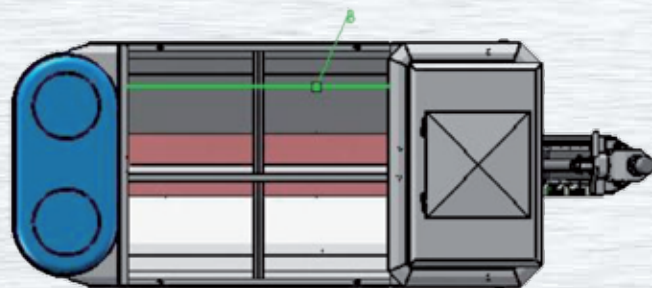

Mixer in transport position. In working operation it can shift about 20° from horizontal position. Moreover, it can rotate about 70° to left and right.



BERTOLI s.r.l.

Zona Industriale S.Stefano
56045 Pomarance (PI) - Italy

Tel. +39-0588-65176 - Fax +39-0588-62749

email: info@bertoli.com

www.bertoli.com